

IR Receiver Modules for Remote Control Systems

Description

The FM-8038 -5DN is miniaturized receiver for infrared remote control system. The PIN Photodiode and preamplifier are assembled on lead frame. The epoxy package is designed as IR filter. The module has excellent performance even in disturbed ambient light application and provides protection against uncontrolled output pulses.



Features

- Transfer Mold Package.
- Supply Voltage Range: 2.7V to 5.5 V
- Supply Current : 0.4mA
- Epoxy IR filter characteristic : 940nm
- Maximum interference safety against optical and electrical disturbance.
- Internal filter for a high frequency lighting fluorescent lamp.
- Internal Pull-Up output.
- Meet RoHS

Application Circuit

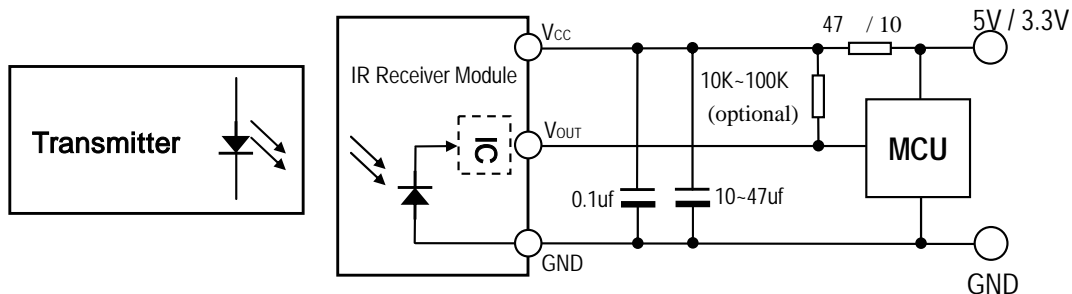

R-C filter recommended to suppress power supply disturbances.
R-C filter should be connected closely between Vcc pin and GND pin.

Block Diagram

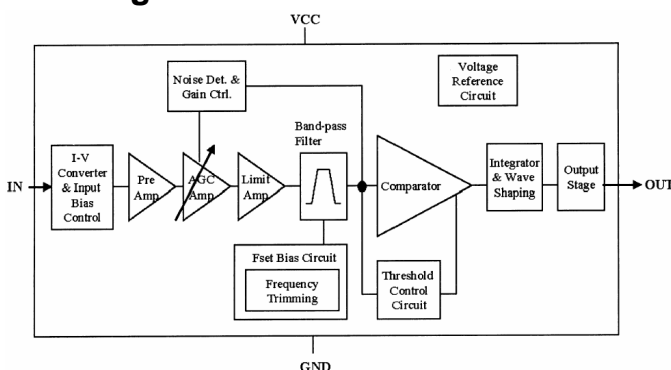

B.P.F Center Frequency

Model No.		Carrier Frequency (fo)
FM-8032	-5DN	32.7 K
FM-8036	-5DN	36.0 K
FM-8038	-5DN	37.9 K
FM-8040	-5DN	40.0 K

Suitable Data Format

NEC code		Toshiba code		Matsushita code	
RC5 code		Sharp code		Mitsubishi code	
RC6 code		Sony 12-bit code		JVC code	
RCMM code		Sony 15-bit code		Continuous code	
RCA code		Sony 20-bit code		Disturbance suppression	

Note : : Best for this application ; : Suitable for this IR code ; : Not recommended

Absolute Maximum Ratings

(Ta = 25 °C)

Parameter	Symbol	Ratings	Unit
Supply Voltage	V _{cc}	6.5	V
Output Current	I _{sink}	1.5	mA
Operating Temperature	T _{opr}	-20 ~ +80	
Storage Temperature	T _{stg}	-30 ~ +85	
Soldering Temperature	T _{sd}	260 °C, Max 5 sec	

Electro-optical Characteristics

(Ta = 25 °C)

Parameter	Symbol	Min.	Typ.	Max.	Unit	Conditions	
Supply Current	ICC	0.3	0.4	0.5	mA	No signal input	
Output Voltage	V _{oh}	V _{cc} -0.5	-	-	V	No external pull-up resistor (I _{sink} < 1mA)	
	V _{ol}	-	0.2	0.4	V		
Peak Wave Length	λ	-	940	-	nm		
Internal Pull-up Resistor	R _{pul}	-	94	-	kΩ		
Arrival Distance	L	±0°	20	-	-	m	Fig 1,2,3
		±30°	15	-	-	m	
		±45°	10	-	-	m	
Output Pulse width	T _{pw}	400	600	800	us	Burst Wave =600us Period = 1.2ms	

[Fig.1] Data Signal diagram

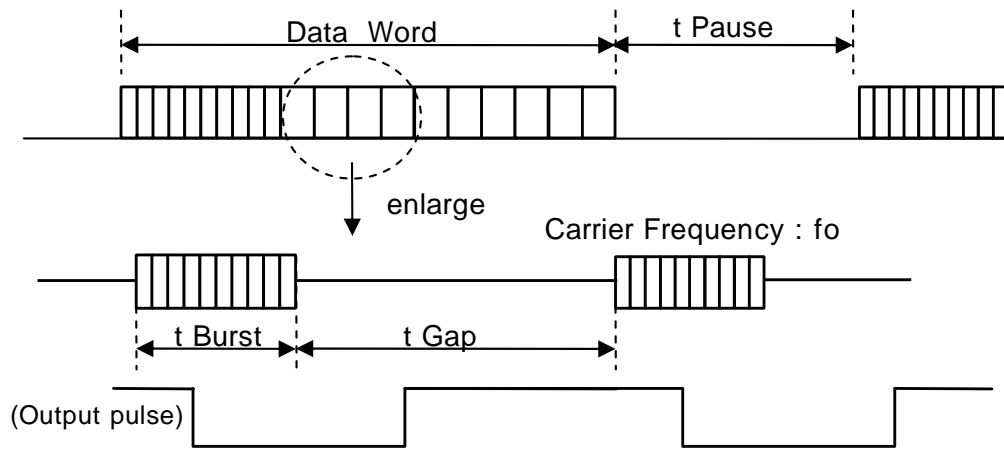

- t Gap : Signal gap time between two burst in pulses of carrier. Minimum Gap Time 16 pulses
- t Burst : Length of a burst in pulses of the carrier frequency. Minimum Burst 12 pulses
- t pause : Data pause between two data words. Minimum Data Pause Time 22ms

[Fig.2] Transmitter

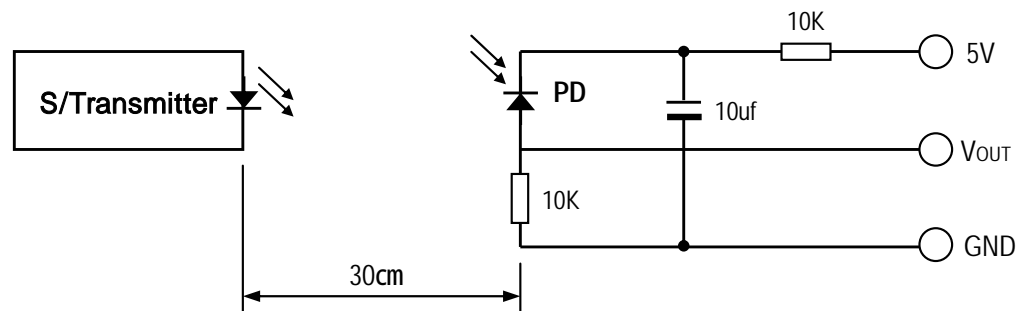

The specifications shall be satisfied under the following conditions. The standard transmitter shall be specified of the burst wave form adjusted to V_{OUT} 200mVp-p upon P_o measuring circuit Standard Transmitter

[Fig.3] Test condition of arrival distance

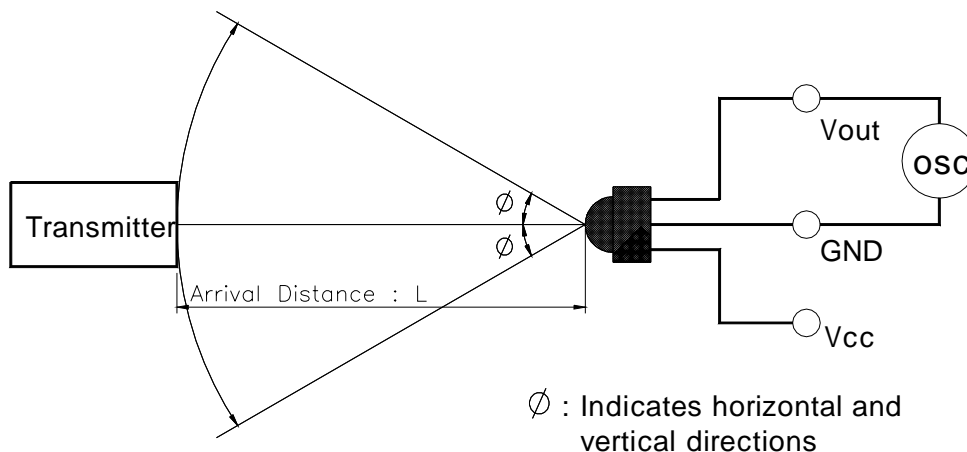

[Measurement condition for arrival distance]

Ambient light source : Detecting surface illumination shall be irradiate 200 ± 50 Lux under ordinary white fluorescence lamp without high frequency lighting

Electrical/Optical Characteristics

[Fig.4] Supply Current vs. Voltage

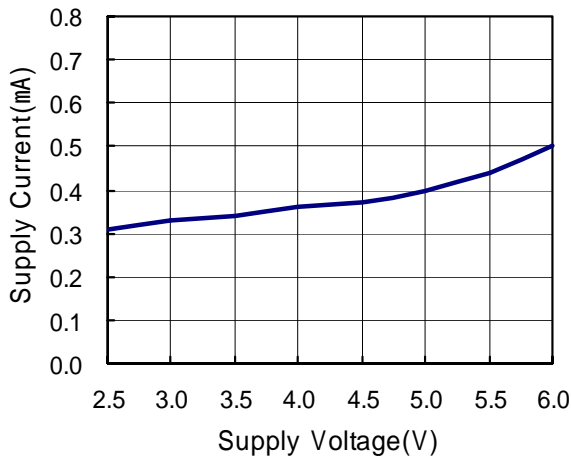

[Fig.5] Relative Spectral Sensitivity vs. Wavelength

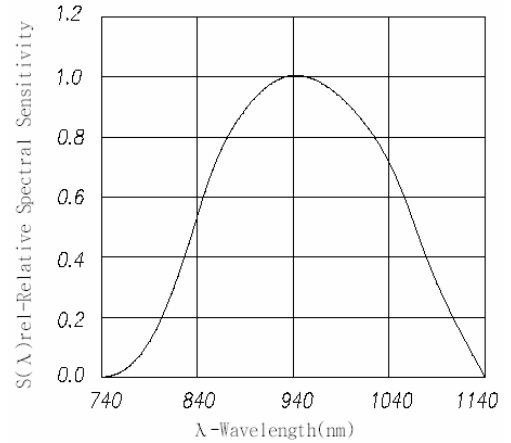

[Fig.6] BPF Fc Curve

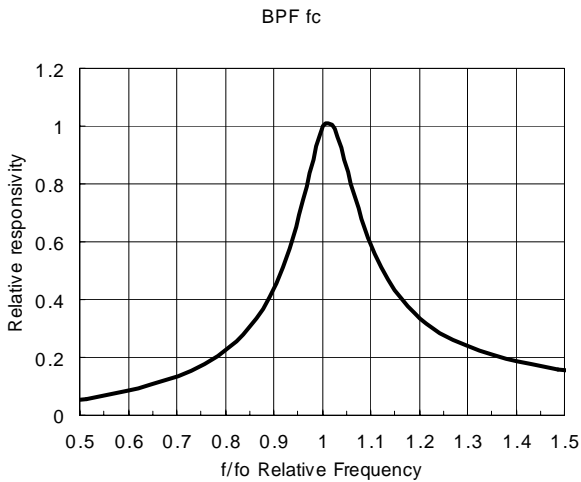

[Fig.7] Directivity (Horizontal/Vertical)

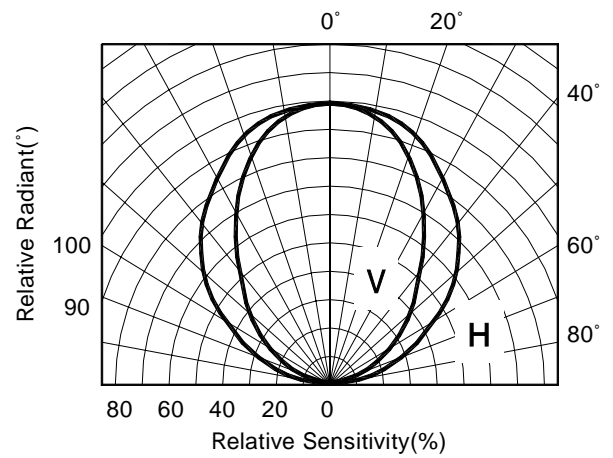

[Fig.8] Sensitivity vs. Supply Voltage

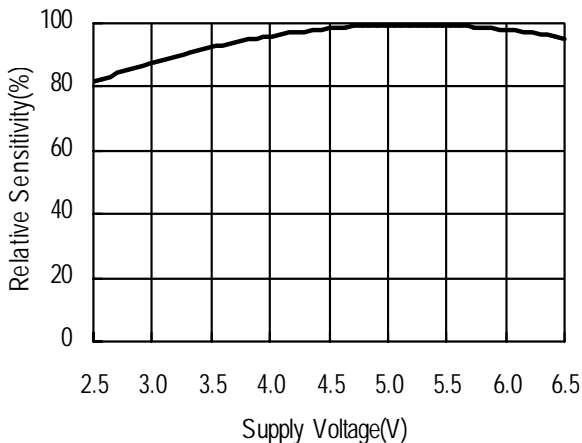

ESD Test Results

Parameter	Conditions	Specification	Results
Machine Model	C=200PF R=0	Min ±200V	>±200V
Human Body Model	C=100PF R=1.5K	Min ±2000V	>±2000V

FM-8038LM-5DN

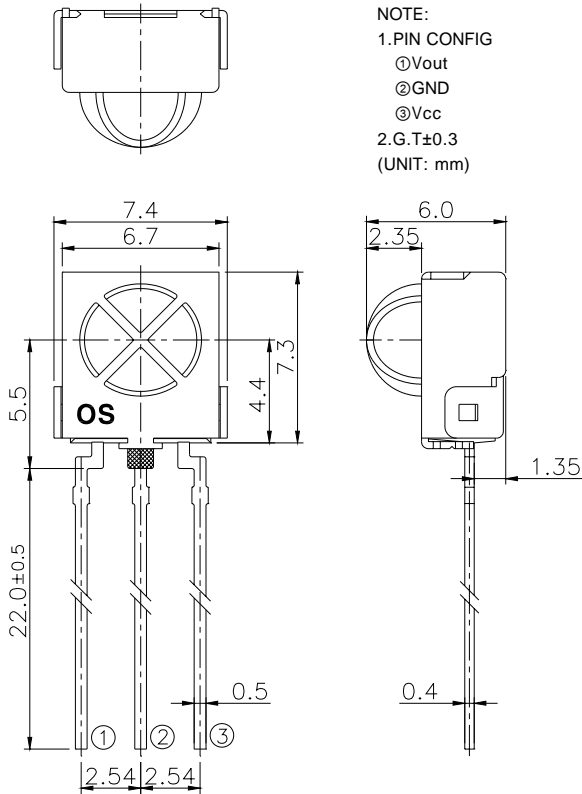

FM-8038TM2-5DN

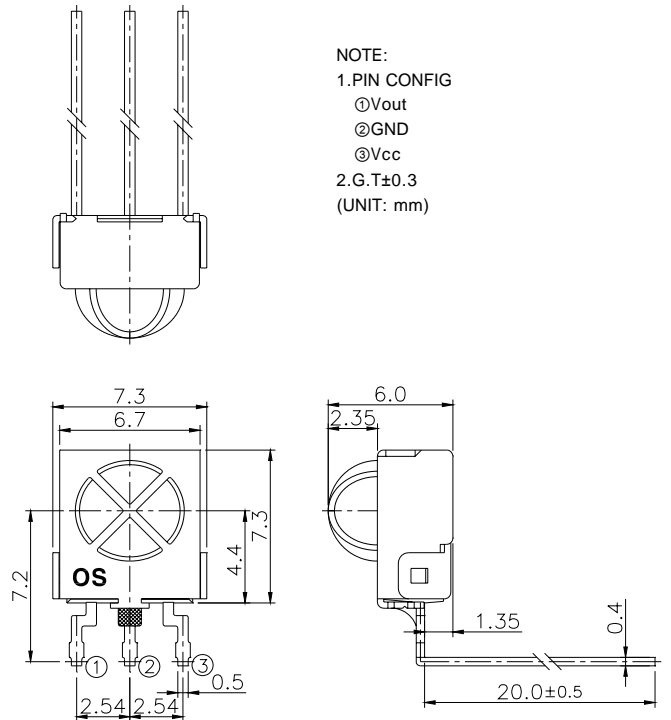

FM-8138SM-5DN

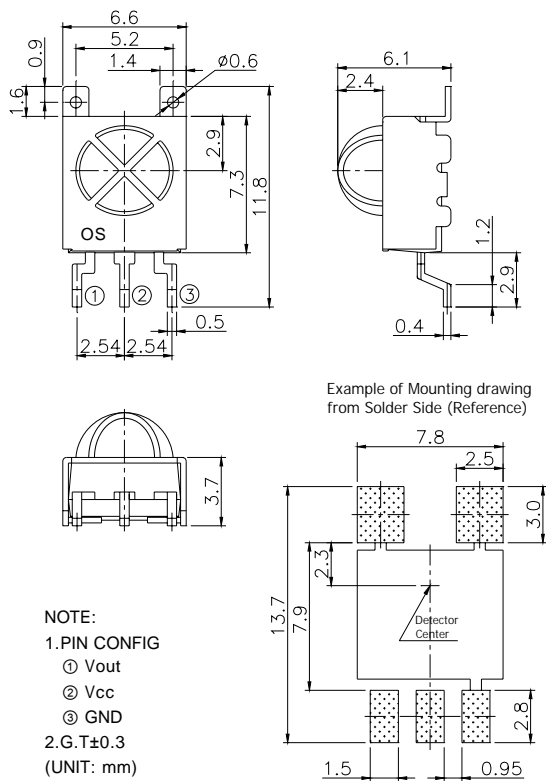

FM-8038SS-5DN

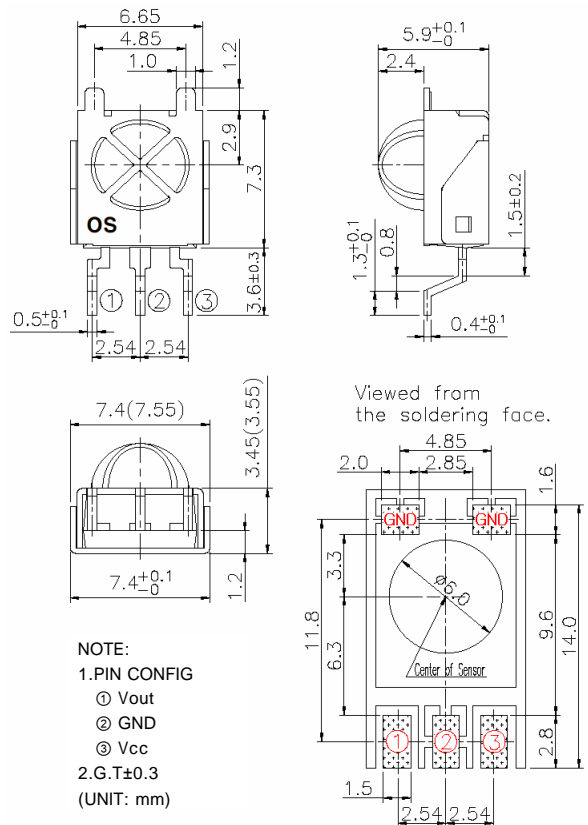

FM-8038SL-5DN

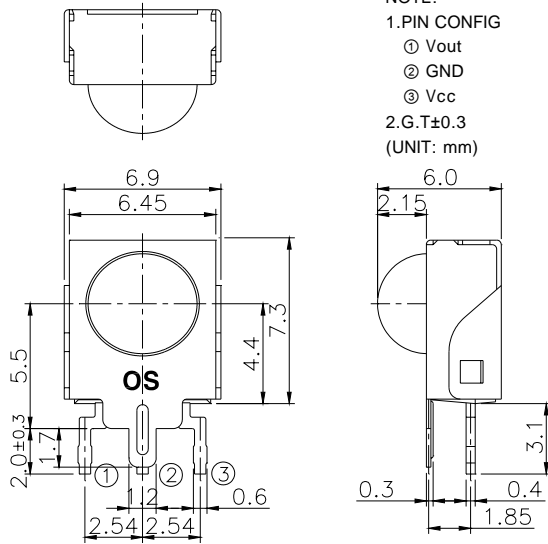

Example of Mounting drawing from Solder Side (Reference)

